

## Side Thrust Pins

for Spring Plungers GN 614, Zinc Die Casting

### SPECIFICATION

#### Types

- Type **LKU**: Fixing from the left, with spring plunger
- Type **RKU**: Fixing from the right, with spring plunger
- Type **BKU**: Fixing from both sides, with spring plunger
- Type **L**: Fixing from the left, without spring plunger
- Type **R**: Fixing from the right, without spring plunger
- Type **B**: Fixing from both sides, without spring plunger

Zinc die casting  
nickel plated

Spring plungers GN 614-KU (see page 847)

Housing

Plastic (Polyacetal POM)

temperature resistant up to 50 °C

Ball Stainless Steel AISI 420C, hardened



### INFORMATION

Holder for spring plungers / Side thrust pins GN 614.1 are used for arresting and as press-on or press-off elements. The easy attachment using one or two countersunk screws also allows its use where a location borehole with the tolerance field H7 for the spring plunger would not be possible from its size and manufacturability.

Side thrust pins GN 614.1 consist of a holder for spring plungers and a Stainless Steel-Spring plunger GN 614 of type KU (see page 847).

For types R, L and B, only a „empty“ holder for spring plungers (without spring plungers) are supplied which can then be used together with all other design variants of GN 614-6 and GN 614-8 of the types KD, MS and NI.

### TECHNICAL INFORMATION

- Stainless Steel characteristics (see page A26)

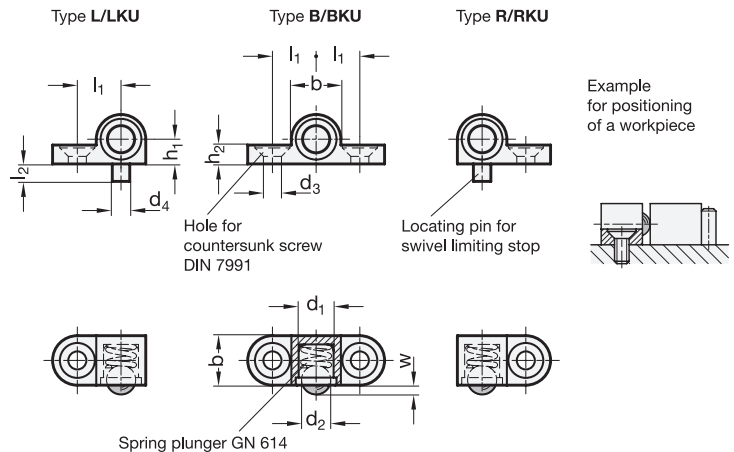

\* Complete with type index of the Holder for spring plungers

LKU    RKU    BKU    L    R    B

### GN 614.1

Description	d1	d2	d3	d4 -0.05	b	h1 ±0.05	h2	l1 ±0.05	l2	w -0.1	Spring load in N ≈ initial	Spring load in N ≈ end	
GN 614.1-6-*	6	5	3.2   M 3	3	8.5	4.25	3.2	7.5	3	1.6	6.5	13	4
GN 614.1-8-*	8	6.5	4.3   M 4	4	10.5	5.25	4.2	9.5	4	1.9	8	18	7

Weight type LKU